



ELSEVIER

Available online at www.sciencedirect.com

SCIENCE @ DIRECT®

Bioorganic Chemistry 32 (2004) 63–75

**BIOORGANIC
CHEMISTRY**

www.elsevier.com/locate/bioorg

Kinetic mechanism of asparagine synthetase from *Vibrio cholerae*

Vicente Fresquet,^a James B. Thoden,^b Hazel M. Holden,^{b,*}
and Frank M. Raushel^{a,*}

^a Department of Chemistry, Texas A&M University, P.O. Box 30012, College Station, TX 77843-3012, USA

^b Department of Biochemistry, University of Wisconsin, Madison, WI 53706, USA

Received 11 June 2003

Abstract

Asparagine synthetase B (AsnB) catalyzes the formation of asparagine in an ATP-dependent reaction using glutamine or ammonia as a nitrogen source. To obtain a better understanding of the catalytic mechanism of this enzyme, we report the cloning, expression, and kinetic analysis of the glutamine- and ammonia-dependent activities of AsnB from *Vibrio cholerae*. Initial velocity, product inhibition, and dead-end inhibition studies were utilized in the construction of a model for the kinetic mechanism of the ammonia- and glutamine-dependent activities. The reaction sequence begins with the ordered addition of ATP and aspartate. Pyrophosphate is released, followed by the addition of ammonia and the release of asparagine and AMP. Glutamine is simultaneously hydrolyzed at a second site and the ammonia intermediate diffuses through an interdomain protein tunnel from the site of production to the site of utilization. The data were also consistent with the dead-end binding of asparagine to the glutamine binding site and PP_i with free enzyme. The rate of hydrolysis of glutamine is largely independent of the activation of aspartate and thus the reaction rates at the two active sites are essentially uncoupled from one another.

© 2003 Elsevier Inc. All rights reserved.

Keywords: Asparagine synthetase B; Dead-end inhibition; Glutamine amidotransferase; Kinetic mechanism

* Corresponding authors. Fax: 1-979-845-9452 (F.M. Raushel), 1-608-262-1319 (H.M. Holden).

E-mail addresses: [hazel_holden@biochem.wisc.edu](mailto: hazel_holden@biochem.wisc.edu) (H.M. Holden), [raushel@tamu.edu](mailto: raushel@tamu.edu) (F.M. Raushel).

1. Introduction

Asparagine synthetase is a key enzyme in the de novo formation of asparagine in eukaryotes and has been associated with resistance to acute lymphoblastic leukemia treatments. Chemotherapy of acute lymphoblastic leukemia involves the administration of multiple drugs, almost always including the enzyme asparaginase where the proposed mechanism of action for asparaginase is the catalytic depletion of cellular asparagine [1]. However, resistant tumors have been reported upon prolonged treatment of asparaginase. Several studies have reported that cellular resistance to asparaginase administration is correlated with elevated expression levels of asparagine synthetase [2–5].

In bacteria there are two unrelated genes (*asnA* and *asnB*) that code for proteins that can synthesize the de novo formation of asparagine. AsnA is present only in prokaryotes and catalyzes the ammonia-dependent synthesis of asparagine [6]. AsnB is present in both eukaryotes and prokaryotes and synthesizes an ATP-dependent conversion of aspartic acid into asparagine using either glutamine or ammonia as the nitrogen source [7]. Previous studies have postulated that the glutamine-dependent synthesis of asparagine takes place via three separate reactions as summarized in Scheme 1. In this mechanism, ammonia is formed through the hydrolysis of glutamine. The activation of aspartate occurs by the formation of a β -aspartyl-AMP¹ intermediate from ATP and then asparagine is formed in the final reaction through a nucleophilic attack of ammonia on the β -aspartyl-AMP intermediate [8].

A comparison of amino acid sequences shows that AsnB belongs to the glutamine amidotransferase family of enzymes. AsnB is a member of the Ntn (*PurF* or Class II) type of glutamine amidotransferases [9], which also includes glutamine phosphoribosylpyrophosphate amidotransferase [10] and glutamine fructose-6-phosphate amidotransferase [11]. This type of glutamine amidotransferase is characterized by an N-terminal cysteine residue that is essential for the hydrolysis of glutamine and formation of ammonia. The three-dimensional X-ray crystal structure of the C1A mutant of AsnB from *Escherichia coli* has been solved in the presence of glutamine and AMP [12]. The enzyme is a homodimer with two active sites separated by a hydrophobic intramolecular tunnel of ~ 20 Å. The C-terminal synthetase domain binds ATP and aspartate and is the site for the formation of the β -aspartyl intermediate and the subsequent reaction with ammonia. The ammonia intermediate has been proposed to diffuse through the interdomain tunnel from the site of production to the site of utilization. The synthetase component has a high degree of homology with GMP synthetase and is included in the category of ATP pyrophosphatases [12].

Several previous attempts have been made to determine the kinetic mechanism of asparagine synthetase [13–17]. However, very different kinetic mechanisms have been proposed depending on the enzyme source and some of these are presented in Scheme 2. For example, a uni-uni-bi-ter ping pong mechanism (Scheme 2A) was

¹ Abbreviations used: AMP-CH₂-PP, α , β -methylene adenosine 5'-triphosphate; AsnA, asparagine synthetase A; AsnB, asparagine synthetase B; CPS, carbamoyl phosphate synthetase.

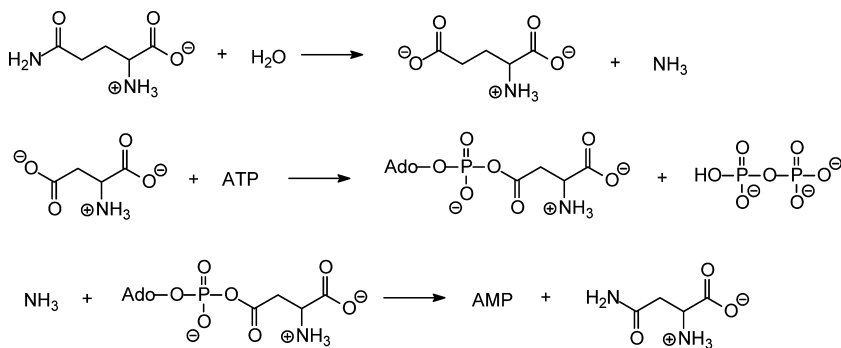

Scheme 1.

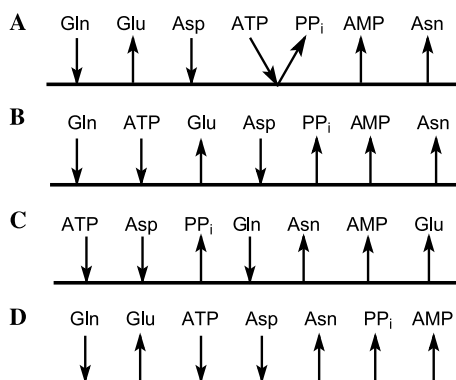

Scheme 2.

described for mouse pancreatic AsnB where glutamine binds first and glutamate is released prior to the binding of ATP and aspartate [13]. An alternative bi-uni-uniter ping pong mechanism (Scheme 2B) has also been proposed where glutamine and ATP bind prior to the release of glutamate and the binding of aspartate [14]. The kinetic mechanism of AsnB from *E. coli* is the only prokaryote enzyme analyzed to date. Two alternative mechanisms that differ in the order of binding and release of glutamine and glutamate have been proposed [15]. These kinetic mechanisms are summarized in Schemes 2C and D. However, the proposed models are unable to adequately explain all of the kinetic data observed with this enzyme. For example, it has been demonstrated that AsnB can hydrolyze glutamine in the absence of the other substrates and catalyzes the synthesis of the β -aspartyl intermediate in the absence of glutamine [15]. In order to obtain a better understanding of the kinetic mechanism of this key enzyme, the bacterial asparagine synthetase from *Vibrio cholerae* was purified and analyzed for the glutamine- and ammonia-dependent synthesis of asparagine.

2. Materials and methods

2.1. Cloning of the *AsnB* gene

Genomic DNA from *V. cholerae* was prepared by standard methods and the *AsnB* gene was PCR amplified such that the forward primer 5'-GGAATTCATATGTGCTCTATCTTTGGCATCTTAG-3' and reverse primer 5'-CCGCTCGAGTTAGTAGGCTTGTGGACG-3' added *NdeI* and *XhoI* cloning sites, respectively. The gene was PCR amplified with Platinum *Pfx* DNA polymerase (Invitrogen) according to the manufacturer's instructions and standard cycling conditions. The PCR product was purified with the QIAquick PCR Purification kit (Qiagen), followed by A-tailing and ligation into pGEM-T Vector (Promega) and transformation into *E. coli* DH5 α cells. The asparagine synthetase gene was sequenced in the pGEM-T vector construct with the ABI Prism Big Dye Primer Cycle Sequencing Kit (Applied Biosystems) to confirm that no mutations were introduced during PCR amplification. The pGEM-T Vector was then digested with *NdeI* and *XhoI* and the gene separated from digestion by-products on a 1.0% agarose gel, excised, and purified with QIAquick Gel Purification kit (Qiagen). The purified asparagine synthetase gene was then ligated into the expression vector pET-31 (Novagen) that was previously cut with the same restriction enzymes. *E. coli* DH5 α cells were transformed with the ligation mixture and then plated onto LB media supplemented with 100 μ g/ml ampicillin. Individual colonies were selected, cultured overnight, and plasmid DNA was extracted with the QIAprep Spin Miniprep Kit (Qiagen). Plasmids were tested for insertion of the *AsnB* gene by digesting with *NdeI* and *XhoI*.

2.2. Protein expression

For protein expression, *E. coli* Rosetta (DE3) cells (Novagen) were transformed with the pET31-*asnB* plasmid and plated onto LB agarose plates supplemented with 100 μ g/ml ampicillin and 30 μ g/ml chloramphenicol. Single colonies from the plates were selected and grown overnight in 500 ml LB media (plus antibiotics) to use for the inoculation of 12 \times 2 L baffled flasks containing 500 ml M9 minimal media (plus antibiotics). The cells were grown at 37 °C with aeration to an OD₆₀₀ of ~0.9, at which time they were cooled on ice for 5 min and transferred to a 16 °C shaker before induction with 1.0 mM IPTG. The cells were allowed to grow for an additional 18 h before harvesting by centrifugation at 6000g for 8 min. The cell paste was frozen in liquid nitrogen and stored at -80 °C.

2.3. Protein purification

All protein purification steps were carried out on ice or at 4 °C. The frozen cell paste was thawed in 3 volumes of 20 mM NaH₂PO₄ (pH 7.5). Cells were lysed on ice by four cycles of sonication (45 s) separated by 5 min of cooling. Cellular debris was removed by centrifugation at 4 °C for 25 min at 20,000g. The clarified lysate was loaded onto a 50 ml fast-flow Q-Sepharose column pre-equilibrated with the lysis

buffer. After loading, the column was washed with about 200 ml of lysis buffer. The protein was then recovered by gradient elution with 0–500 mM KCl in the lysis buffer. Protein containing fractions were pooled based on SDS–PAGE. The pooled fractions were diluted with three volumes of lysis buffer and passed over a 50 ml Green-19 column to remove minor contaminants. The protein was again pooled on the basis of SDS–PAGE, concentrated, and dialyzed against 20 mM Hepes (pH 7.5) containing 100 mM NaCl. The dialyzed protein was concentrated to approximately 10 mg/ml, based on an extinction coefficient of ~ 0.79 ml/(mg cm) as calculated by the program Protean (DNAstar, Madison, WI).

2.4. Asparagine synthetase activity

The asparagine synthetase activity was measured using a myokinase/pyruvate kinase/lactic dehydrogenase coupled assay by following the loss of NADH spectrophotometrically [18]. The assay was carried out at 30 °C using 100 mM Hepes, pH 8.0, 100 mM KCl, 1.0 mM dithiothreitol (DTT), 28 μ g/ml lactic dehydrogenase, 28 μ g/ml pyruvate kinase, 0.5 U myokinase, 10 mM MgSO₄, 1.0 mM phosphoenolpyruvate, 0.44 mM NADH, and 1–10 μ g of asparagine synthetase. When glutamine, ammonia, ATP or aspartate was varied, the concentration range was: 0.05–15 mM, 1–50 mM, 0.05–10 mM, and 0.1–20 mM, respectively.

In the inhibition studies by AMP the activity was quantified by monitoring the formation of pyrophosphate with a fructose-6-phosphate pyrophosphate-dependent kinase (PP_i-PFK), aldolase, triose phosphate isomerase (TPI), and glycerol phosphate dehydrogenase (GDH) coupled assay. The activity was measured at 30 °C in 250 μ l containing 100 mM Hepes, pH 8.0, 100 mM KCl, 1.0 mM DTT, 10 mM MgSO₄, 5.0 mM D-fructose-6-phosphate, 0.25 U PP_i-PFK, 1.0 U aldolase, 0.5 U GDH, 5 U TPI, 0.44 mM NADH, and 1–10 μ g of asparagine synthetase.

2.5. Glutaminase activity

The amount of glutamate produced was determined using glutamate dehydrogenase as the coupling enzyme in the presence of 3-acetylpyrimidine adenine nucleoside (APAD). The reaction mixtures (200 μ l) contained 100 mM Hepes, pH 8.0, 100 mM KCl, 1.0 mM DTT, 10 mM MgCl₂ with a variable concentration of glutamine (0.05–10 mM). Reactions were initiated by adding AsnB (5.4 μ g) and incubating for 20 min at 30 °C and then quenched by the addition of 75 μ l of 10% TCA. After neutralizing by the addition of 15 μ l of 3 M Trizma base, a 75 μ l portion of the reaction mixture was added to 400 μ l of the coupling reagent (0.12 M Hepes, pH 8.0, 0.12 M KCl, 12 U of glutamate dehydrogenase, and 1.2 mM APAD). After 2 h of incubation the absorbance was measured at 363 nm.

2.6. Asparaginase activity

The hydrolysis of asparagine was measured spectrophotometrically by coupling the formation of aspartate to the oxidation of NADH using malate dehydrogenase

and aspartate aminotransferase as previously described [19]. The reaction was conducted in a volume of 250 μ l at 30 °C in a reaction mixture containing 100 mM HEPES, pH 8.0, 100 mM KCl, 1.0 mM DTT, 10 mM MgCl₂, 3.7 mM α -ketoglutarate, 0.4 mM NADH, 0.36 U malate dehydrogenase, and 6 U aspartate aminotransferase.

2.7. Data analysis

Initial velocity data with a single substrate were fitted to Eq. (1). Initial velocity data with two substrates conforming to an intersecting pattern were fitted to Eq. (2) and a parallel pattern to Eq. (3). Competitive, uncompetitive, and noncompetitive inhibition patterns were fitted to Eqs. (4)–(6), respectively.

$$v = (V_{\max}[\text{A}]) / (K_a + [\text{A}]), \quad (1)$$

$$v = (V_{\max}[\text{A}][\text{B}]) / (K_{ia}K_b + K_b[\text{A}] + K_a[\text{B}] + [\text{A}][\text{B}]), \quad (2)$$

$$v = (V_{\max}[\text{A}][\text{B}]) / (K_a[\text{B}] + K_b[\text{A}] + [\text{A}][\text{B}]), \quad (3)$$

$$v = (V_{\max}[\text{A}] / (K_a(1 + [I]/K_{is}) + [\text{A}])), \quad (4)$$

$$v = (V_{\max}[\text{A}] / (K_a(1 + [I]/K_{is}) + [\text{A}](1 + [I]/K_{ii}))), \quad (5)$$

$$v = (V_{\max}[\text{A}] / (K_a + [\text{A}](1 + [I]/K_{ii}))). \quad (6)$$

3. Results

3.1. Initial velocity studies

The kinetic mechanism of asparagine synthetase was probed by measuring the initial velocities of the reaction while simultaneously varying the concentration of two substrates and holding the third substrate constant. The data were fitted to Eq. (2) or Eq. (3) and visualized as double reciprocal plots. Both ammonia and glutamine were used as alternate sources of nitrogen and the results are summarized in Table 1. When glutamine was used as the nitrogen source, the ATP versus aspartate double reciprocal plot was intersecting, indicating that there was not an irreversible step between the binding of these two substrates to the enzyme active site [20,21]. When ammonia was used as the nitrogen source the double reciprocal plots between ATP and aspartate versus ammonia were parallel. These results indicate that there was an irreversible step between the addition of free ammonia and the other two substrates to the enzyme active site. When glutamine was used as the nitrogen source, the double reciprocal plots for ATP and aspartate versus glutamine were also parallel. The overall k_{cat} values at saturating substrate concentrations of all substrates were 4.2 ± 0.1 and $3.4 \pm 0.1 \text{ s}^{-1}$ for the glutamine- and ammonia-dependent synthesis of asparagine, respectively.

Table 1
Kinetic parameters from the initial velocity patterns for combinations of substrates^a

Substrate pair	Gln		Ammonia		ATP		Aspartate		Pattern
	K_d (mM)	K_c (mM)	K_a (μ M)	K_{ia} (μ M)	K_b (mM)	K_{ib} (mM)			
Gln-ATP	0.5 \pm 0.02		95 \pm 5						P ^c
Gln-Asp	0.8 \pm 0.07						0.9 \pm 0.04		P
NH ₃ -ATP			11 \pm 0.9		94 \pm 6				P
NH ₃ -Asp			13 \pm 0.6				0.8 \pm 0.03		P
ATP-Asp ^b			122 \pm 7		17 \pm 4		1.0 \pm 0.06 0.14 \pm 0.05		I ^d

^a The activity was determined monitoring the rate of AMP formation.

^b Glutamine was used as the nitrogen source.

^c A fit of the data to Eq. (3).

^d A fit of the data to Eq. (2).

3.2. Inhibition by substrate analogs

The initial velocity studies were unable to distinguish whether the binding of ATP and aspartate to the enzyme was sequential or random. Chemically unreactive mimics of ATP and aspartate were therefore used as dead-end inhibitors to help determine the order of substrate binding to asparagine synthetase. α , β -Methylene adenosine 5'-triphosphate (AMP-CH₂-PP) was utilized as a mimic for ATP. This compound was competitive versus ATP and noncompetitive versus aspartate. Uncompetitive patterns were obtained versus glutamine and ammonia. The first aspartate analog to be tested was β -methyl aspartate as a mixture of four diastereomers (Sigma). Although (2*S*,3*R*) β -methyl aspartate has been reported to inhibit asparagine synthetase from *E. coli* [22], no inhibition was detected for the unfractionated mixture of stereoisomers with AsnB from *V. cholerae* up to a concentration of 20 mM. However, L-cysteine sulfinic acid was found to be a good competitive inhibitor with respect to aspartate and uncompetitive versus ATP. Uncompetitive inhibition was observed versus ammonia. No inhibition of the partial glutaminase reaction was detected using L-cysteine sulfinic acid. When this compound was tested as an alternate substrate for aspartate, a very slow production of AMP was detected that was less than 0.5% of the overall rate observed with aspartate. This latter result is in agreement with previous work carried out with the *E. coli* enzyme [18]. The dead-end inhibition patterns by AMP-CH₂-PP and L-cysteine sulfinic acid are consistent with the ordered addition of ATP to free enzyme followed by aspartate. The γ -methyl ester of glutamic acid was utilized as a mimic of glutamine. This compound was a weak competitive inhibitor versus glutamine and ammonia and uncompetitive versus ATP and aspartate. All of the dead-end inhibition data are summarized in Table 2.

3.3. Product inhibition

Product inhibition studies were carried out in an attempt to obtain more information on the order of product release from the active site. Glutamate and AMP were

Table 2
Inhibition by product and substrate analogs

Inhibitor	Substrate	K_{is}	K_{ii}	Pattern
PP _i	ATP	0.021 ± 0.02		C
	Asp	0.85 ± 0.15	0.65 ± 0.05	NC
	NH ₃		0.85 ± 0.09	UC
	Gln		0.85 ± 0.06	UC
Asn	Gln	0.023 ± 0.003		C
AMP-CH ₂ -PP	ATP	1.1 ± 0.2		C
	Asp	2.6 ± 0.7	2.6 ± 0.4	NC
	Gln		3.2 ± 0.2	UC
	NH ₃		3.7 ± 0.3	UC
L-Cysteine sulfinic acid	ATP		2.5 ± 0.1	UC
	Asp	1.1 ± 0.1		C
	Gln	7.2 ± 1.2	6.4 ± 0.4	NC
	NH ₃		2.2 ± 0.1	UC
L-glutamic acid γ -methyl ester	ATP		29 ± 3	UC
	Asp		27 ± 3	UC
	Gln	8.9 ± 0.9		C
	NH ₃	6.5 ± 0.7		C

When ATP or Asp was varied, ammonia was used as nitrogen source. The data of competitive (C), uncompetitive (UC) or noncompetitive (NC) patterns were fitted to Eq. (4)–(6), respectively.

unable to inhibit AsnB up to concentrations of 80 and 12 mM, respectively. However, pyrophosphate and asparagine were good inhibitors of the enzyme. Pyrophosphate was a competitive, noncompetitive, and uncompetitive inhibitor versus ATP, aspartate, and ammonia, respectively. This set of inhibition patterns for PP_i versus these three substrates is identical to the collection of inhibition patterns obtained for the ATP analog, AMP-CH₂-PP. This result is consistent with the conclusion that PP_i is acting as a general dead-end inhibitor that binds to free enzyme rather than as a typical product inhibitor.

Asparagine inhibited the ammonia- and glutamine-dependent activities. However, the inhibition was different in each case and is illustrated in Fig. 1. Asparagine inhibited completely the glutamine-dependent activity. However, the inhibition of the ammonia-dependent activity was only partial. This behavior suggests that asparagine binds predominantly to the site for glutamine. When the asparagine inhibition of the glutaminase partial reaction was analyzed, a competitive inhibition pattern versus glutamine was obtained, with a K_i value of 60 μ M. This result demonstrates that the inhibition of the glutamine-dependent reaction by asparagine is predominantly a consequence of binding directly to the glutamine binding site. The kinetic parameters for the inhibition by products are presented in Table 2.

The observation of asparagine binding to the glutamine site, suggested that AsnB may have an asparaginase activity. In order to determine if the enzyme was able to hydrolyze asparagine, this activity was measured in absence of the other substrates. A small production of aspartate was detected with a K_m of 0.9 ± 0.2 mM and a k_{cat} of 0.07 ± 0.007 s⁻¹. However, this activity was not inhibited by the addition of saturating concentrations of the other substrates or substrate analogs. Therefore, it cannot

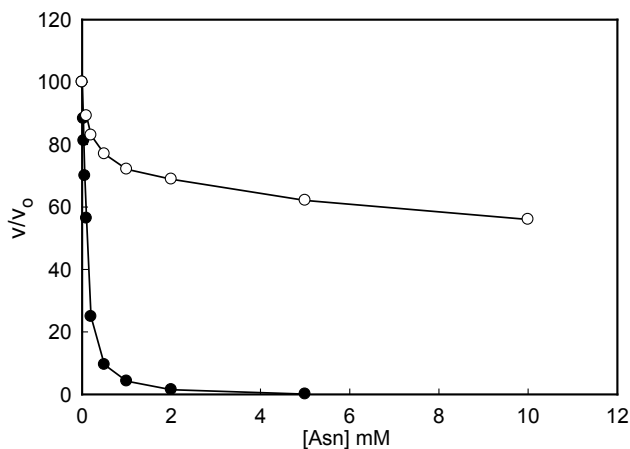

Fig. 1. Inhibition of the glutamine- (●) and ammonia- (○) dependent activities by asparagine. Additional details are provided in the text.

Table 3
Kinetic parameters for the hydrolysis of glutamine^{a,b}

Substrate combinations	K_d (mM)	k_{cat} (s^{-1})
Glutamine	0.63 ± 0.04	3.9 ± 0.1
Glutamine + ATP	0.97 ± 0.06	5.6 ± 0.1
Glutamine + ATP + Asp	1.6 ± 0.3	5.8 ± 0.2

^aThe activity was monitored by the following the production of glutamate in the presence or absence of 5.0 mM ATP and 5.0 mM aspartate.

^bThe data were fitted using Eq. (1).

be determined from these data whether or not the very low level of asparagine hydrolysis is the result of a contamination by an asparaginase.

It has been reported that AsnB from *E. coli* is different from other glutamine amidotransferases in that the rate of glutamine hydrolysis is not fully coupled with the synthesis of asparagine [23]. In the *E. coli* enzyme, a stoichiometric relationship of 1.3–1.5 glutamate/PP_i is produced at saturating concentrations of the substrates [15]. In order to determine whether the AsnB from *V. cholerae* has this characteristic stoichiometry, the partial glutaminase activity was measured in the presence and absence of the other two substrates. As shown in the Table 3, the kinetic parameters for the glutaminase activity do not change significantly in the presence of ATP and aspartate. The relative rate of the glutaminase activity is higher than unity, indicating that the reactions are partially uncoupled from one another.

4. Discussion

We report in this paper the cloning, expression, and purification of asparagine synthetase from *V. cholerae*. This enzyme catalyzes a reaction that requires three

different substrates with the net production of four products and two reactive intermediates. The chemistry takes place within two different active sites that are separated in three-dimensional space by approximately 20 Å. In order to more fully understand this complex reaction mechanism we have analyzed both the glutamine- and ammonia-dependent activities. The analysis of the ammonia-dependent synthesis of asparagine is somewhat easier to manage since all of the chemistry is occurring within a single active site. When glutamine is used as a nitrogen source, different chemical reactions can occur simultaneously at the individual active sites connected by the interdomain molecular tunnel.

Two sets of parallel double reciprocal plots were obtained when either ATP or aspartate was varied versus ammonia. This result is consistent with the irreversible release of a product between the binding of ammonia and the other two substrates. Given the likely chemical mechanism for this transformation, pyrophosphate is therefore proposed to be the product formed immediately after the binding of ATP and aspartate. The binding of ATP and aspartate could either be ordered or random. In order to decide between these two possibilities, two different dead-end substrate mimics of ATP and aspartate were utilized. The non-hydrolyzable ATP analog, AMP-CH₂-PP, was found to be competitive versus ATP and noncompetitive versus aspartate. In contrast, cysteine sulfinic acid was competitive versus aspartate and uncompetitive versus ATP. This set of inhibition patterns is only consistent with the ordered binding of ATP prior to the addition of aspartate to the enzyme. The uncompetitive inhibition patterns by the dead-end inhibitors AMP-CH₂-PP and cysteine sulfinic acid versus ammonia are also fully consistent with the release of pyrophosphate prior to the binding of ammonia [21]. Once ATP and aspartate have bound to the enzyme, PP_i and the β-aspartyl-AMP intermediate are formed following nucleophilic attack by the side chain carboxylate of aspartic acid on the α-phosphoryl group of ATP. Pyrophosphate is released and ammonia binds to the synthetase active site where it reacts with the β-aspartyl-AMP intermediate to form asparagine and AMP.

The determination of the order of asparagine and AMP release from the active site was attempted by using these compounds as product inhibitors. However, these two compounds did not behave as typical product inhibitors of the forward reaction. With AMP no inhibition was observed up to a concentration of 12 mM. In contrast, asparagine was found to be a very good inhibitor of the reaction when glutamine was used as the nitrogen source. The inhibition versus glutamine was competitive and thus the primary mode for the inhibition exhibited by asparagine is via binding directly to the glutamine site within the glutaminase domain and not through a direct interaction with the synthetase domain. Moreover, the inhibition of the overall reaction by high concentrations of asparagine when ammonia is used as the nitrogen source is only partial. From these results it can be concluded that asparagine cannot be used as a product inhibitor since it apparently does not bind to the synthetase domain at reasonable concentrations. This situation is probably exacerbated by the rather weak binding of AMP to free enzyme. Nevertheless, we propose that asparagine is released prior to the dissociation of AMP. This conclusion is based entirely on the symmetry of the reaction whereby ATP has been shown to bind prior to the addition of aspartate.

The reaction mechanism when glutamine is used as the nitrogen-source is similar. Parallel double reciprocal patterns were obtained when glutamine was varied versus ATP or aspartate. This is the expected result for a two-site ping pong mechanism when glutamine can bind to the glutaminase domain independently from the binding of the other two substrates within the synthetase domain. However, we have obtained no data that enables us to determine the timing for the release of glutamate. A similar situation is observed in the steady state kinetic analysis of the reaction catalyzed by carbamoyl phosphate synthetase (CPS) where the double reciprocal plots for glutamine versus either ATP or bicarbonate are parallel [24]. However, there are some significant differences observed for the interplay between the glutaminase domain and the synthetase domain for asparagine synthetase and that previously observed for comparable domains within carbamoyl phosphate synthetase. With CPS a conformational change that is triggered by the binding and reaction of ATP and bicarbonate significantly enhances the rate of ammonia production from the hydrolysis of glutamine. With asparagine synthetase the rate of glutamine hydrolysis is apparently independent of the binding of ATP and/or aspartate to the synthetase domain. With CPS, the triggering mechanism serves as a mechanical device for ensuring that the proper stoichiometry is maintained throughout the reaction cycle. Thus, ammonia is not injected into the interdomain tunnel until the reactive carboxy phosphate intermediate is waiting at the other end. With asparagine synthetase the rate of glutamine hydrolysis does not seem to be coupled to events within the synthetase domain and thus the stoichiometry must be maintained by the inherent catalytic efficiency of the two sites. The overall kinetic mechanism for asparagine synthetase from *V. cholerae*, including the formation of two dead-end complexes, is summarized in Scheme 3.

The kinetic model proposed in this paper is in general agreement with previous experiments conducted with other asparagine synthetases and is able to explain some peculiar catalytic features of this enzyme. Isotope trapping studies demonstrated that AsnB from *E. coli* is able to synthesize the β -aspartyl intermediate in the absence of

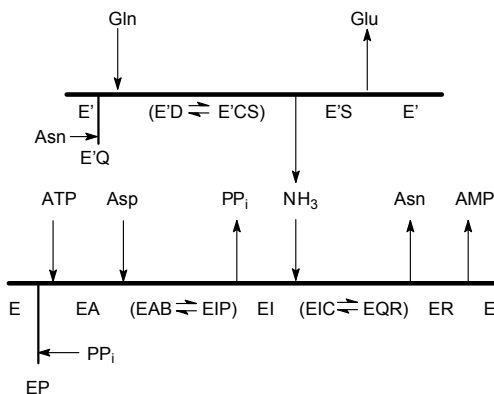

Scheme 3.

nitrogen source [15]. These same studies are also consistent with the ordered binding of ATP and aspartate in the absence of any nitrogen source. The inhibition of the ammonia-dependent activity is consistent with the binding of asparagine to the glutamine site. Mutagenesis of the cysteine 1 to alanine produces a protein that is unable to synthesize asparagine from glutamine but with a normal activity when ammonia is used as substrate. The binding of glutamine to this asparagine synthetase mutant inhibits the ammonia-dependent activity [25,26].

Acknowledgments

We thank Dr. John Lindquist (Department of Bacteriology, University of Wisconsin-Madison) for supplying *V. cholerae* cell stock. This work was supported in part by the NIH (DK 30343) and (GM 55513) and the Robert A. Welch Foundation (A-840).

References

- [1] R. Chakrabarti, S.M. Schuster, *Int. J. Pediatric Hematol. Oncol.* 4 (1997) 597–611.
- [2] R. Pieters, E. Klumper, G.J.L. Kaspers, A.J.P. Veerman, *ASP Crit. Rev. Oncol. Hematol.* 25 (1997) 11–26.
- [3] G.J.L. Kaspers, R. Pieters, C.H. Van Zantwijk, E.R. Van Wering, A. Van Der Does-Van Der Berg, A.J.P. Veerman, *Blood* 92 (1998) 259–266.
- [4] R.G. Hutson, T. Kitoh, D.A.M. Amador, S. Cosic, S.M. Schuster, M.S. Kilberg, *Am. J. Physiol.* 272 (1997) C1691–C1699.
- [5] A.M. Aslanian, B.S. Fletcher, M.S. Kilberg, *Biochem. J.* 357 (2001) 321–328.
- [6] H. Cedar, J.H. Schwartz, *J. Biol. Chem.* 244 (1969) 4112–4121.
- [7] H.A. Milman, D.A. Cooney, *Biochem. J.* 181 (1979) 51–59.
- [8] N.G. Richards, S.M. Schuster, *Adv. Enzymol.* 72 (1998) 145–198.
- [9] H. Zalkin, J.L. Smith, *Adv. Enzymol. Relat. Areas Mol. Biol.* 72 (1998) 87–144.
- [10] J.Y. Tso, M.A. Hermodson, H. Zalkin, *J. Biol. Chem.* 257 (1982) 3532–3536.
- [11] K.O. Broschat, C. Gorka, J.D. Page, C.L. Martin-Berger, M.S. Davies, H. Huang, E.A. Gulve, W.J. Salsgiver, T.P. Kasten, *J. Biol. Chem.* 277 (2002) 14764–14770.
- [12] T.M. Larsen, S.K. Boehlein, S.M. Schuster, N.G.J. Richards, J.B. Thoden, H.M. Holden, I. Rayment, *Biochemistry* 38 (1999) 16146–16157.
- [13] H.A. Milman, D.A. Cooney, C.Y. Huang, *J. Biol. Chem.* 255 (1980) 1862–1866.
- [14] R.S. Markin, C.A. Luehr, S.M. Schuster, *Biochemistry* 20 (1981) 7226–7232.
- [15] S.K. Boehlein, J.D. Stewart, E.S. Walworth, R. Thirumoorthy, N.G.J. Richards, S.M. Schuster, *Biochemistry* 37 (1998) 13230–13238.
- [16] P.M. Mehlhaff, C.A. Luehr, S.M. Schuster, *Biochemistry* 24 (1985) 1104–1110.
- [17] S. Hongo, T. Sato, *Arch. Biochem. Biophys.* 238 (1985) 410–417.
- [18] S.K. Boehlein, T. Nakatsu, J. Hiratake, R. Thirumoorthy, J.D. Stewart, N.G.J. Richards, S.M. Schuster, *Biochemistry* 40 (2001) 11168–11175.
- [19] J.B. Thoden, R. Marti-Arbona, F.M. Raushel, H.M. Holden, *Biochemistry* 42 (2003) 4874–4882.
- [20] W.W. Cleland, *Biochim. Biophys. Acta* 67 (1967) 104–137.
- [21] W.W. Cleland, in: P.D. Boyer (Ed.), *The Enzymes*, Academic Press, 1970, pp. 1–70.
- [22] I.B. Parr, S.K. Boehlein, A.B. Dribben, S.M. Schuster, N.G.J. Richards, *J. Med. Chem.* 39 (1996) 2367–2378.
- [23] A.R. Tesson, T.S. Soper, M. Ciustea, N.G. Richards, *Arch. Biochem. Biophys.* 413 (2003) 23–31.

- [24] F.M. Raushel, P.M. Anderson, J.J. Villafranca, *Biochemistry* 17 (1978) 5587–5591.
- [25] S.K. Boehlein, N.G.J. Richards, S.M. Schuster, *J. Biol. Chem.* 269 (1994) 7450–7457.
- [26] S. Sheng, D.A. Moraga-Amador, G. van Heeke, R.D. Allison, N.G. Richards, S.M. Schuster, *J. Biol. Chem.* 268 (1993) 16771–16780.